



# Pump Monitor Relay PMR2

MADE IN  
THE U.S.A.



UL FILE #E101681

## OPERATION

The PMR2 Pump Monitor Relay provides Motor Over Temperature and Seal Leakage alarms for submersible pumps equipped with FLS or CLS sensors.

The PMR2 applies 12 VDC to the sensor and measures the current flow through the sensor. The sensor controls the current in the circuit. If the sensor current is in the normal range the Temperature Alarm Relay is energized to allow normal pump operation. If the sensor circuit becomes shorted, the 12 VDC is turned off and all LEDs flash.

Upon a High Motor Temperature condition, the sensor opens so that the sensor circuit current drops to zero. With the sensor current below the Trip Point ( $\leq 3.0 \text{ mA} \pm 5\%$ ), the Overtemp Indication is turned on and the Temperature Alarm Relay is de-energized, preventing pump operation.

When the High Motor Temperature condition has cleared, the unit will reset based on the position of Alarm Reset Mode Select Switch (Auto or Manual). When in the Auto position, the Overtemp Alarm resets automatically. If the switch is in the Manual position, the Overtemp Reset Push-button must be pushed to clear the alarm.

Upon a Seal Leakage condition, the sensor increases the sensor circuit current above the Trip Point ( $\geq 22 \text{ mA} \pm 5\%$ ), the Leakage Indication is turned on and the Leakage Alarm Relay is energized.

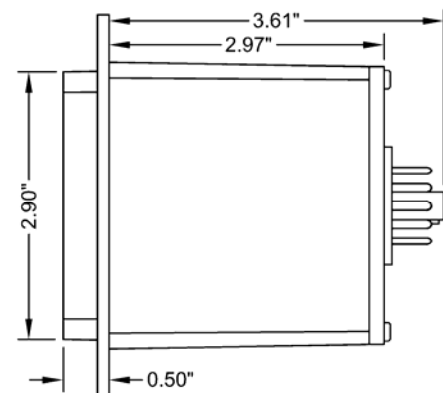
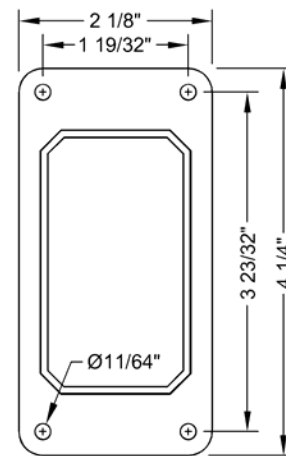

## SPECIFICATIONS

|                         |   |
|-------------------------|---|
| Input Power:            | 120 VAC $\pm 10\%$ , 7.0 VA max<br>24 VAC $\pm 10\%$ , 3.5 VA max<br>24 VDC $\pm 10\%$ , 125 mA max |
| Output Rating:          | 8A Resistive @ 120VAC   |
| Operating Temp:         | -20 °C to +65 °C  |
| Storage Temp:           | -45 °C to +85 °C  |
| Sensor Circuit Voltage: | 12 VDC $\pm 10\%$   |
| Temp Alarm Trip Point:  | $\leq 3.0 \text{ mA} \pm 5\%$   |
| Leak Alarm Trip Point:  | $\geq 22 \text{ mA} \pm 5\%$  |
| Enclosure:              | Blue Lexan  |
| Base:                   | Phenolic  |

## ORDERING INFORMATION

Part Number: PMR2

# Pump Monitor Relay PMR2

## CONNECTION DIAGRAM

